



Industrial Frigo

SIREV 1-260/500/Z

SISTEMA INTEGRATO DI REFRIGERAZIONE ECONOMIZZATORE

Resa frigorifera nominale Nominal cooling capacity Puissance frigorifique nominale Nennkühlleistung Capacidad enfriamiento nominal		Potenza compressori Compressors power Puissance compresseurs Kompressoren Leistung Potencia compresores			Utenza - User - Usager - Benutzer - Usuario									
kW	kcal/h	n°	nom. max.		kW ass./inst.	Potenza pompa Pump power Puissance pompe Pumpenleistung Potencia bomba			Portata pompa Pump flow Débit pompe Pumpe Durchflußmenge Caudal bomba			Prevalenza pompa Pump pressure Pression pompe Pumpendruck Presión bomba		
			kW ass.	kW inst.		kW ass./inst.	min.	l/min nom.	max.	min.	l/min nom.	max.	max.	bar nom.
250	215.000	2x	21,0	35,7	3,0/4,0	500	720	1100	2,35	2,1	1,5			

Resa frigorifera $\Delta T5$ Cooling capacity $\Delta T5$ Puissance frigorifique $\Delta T5$ Nennkühlleistung $\Delta T5$ Capacidad enfriamiento $\Delta T5$		Ricircolo - Recycle - Recirculation - Widerlauf - Recirculacion						Potenza ventilatori Fans power Puissance ventilateurs Vent. Durchflußmenge Caudal ventiladores			Portata ventilatori Fan flow rate Débit ventilateur Tragfähigkeit Ventilator Caudal ventilador			
kW	kcal/h	kW ass./inst.	Potenza pompa Pump power Puissance pompe Pumpenleistung Potencia bomba			Portata pompa Pump flow Débit pompe Pumpe Durchflußmenge Caudal bomba			Prevalenza pompa Pump pressure Pression pompe Pumpendruck Presión bomba			n°	kW ass./inst.	m³/h
			min.	l/min nom.	max.	min.	l/min nom.	max.	bar nom.	min.				
280	240.000	2,7/3,0	400	800	1000	1,85	1,55	1,15	8x	1,3/1,5	130.000			

Rumorosità Noise Bruit Geräusch Ruido		Peso con acqua Weight with water Poids avec eau Gewicht mit Wasser Peso con agua	Dimensioni imballo Packaging dimensions Dimensions emballage Verpackungsabmessung. Dimensiones embalaje	Peso imballo Packaging weight Poids emballage Verpackungsgewicht Peso embalaje
UNI 7712 dB(A)				
1m	10m	kg	mm	kg
89	69	3.800	4100x2400x2300h	800

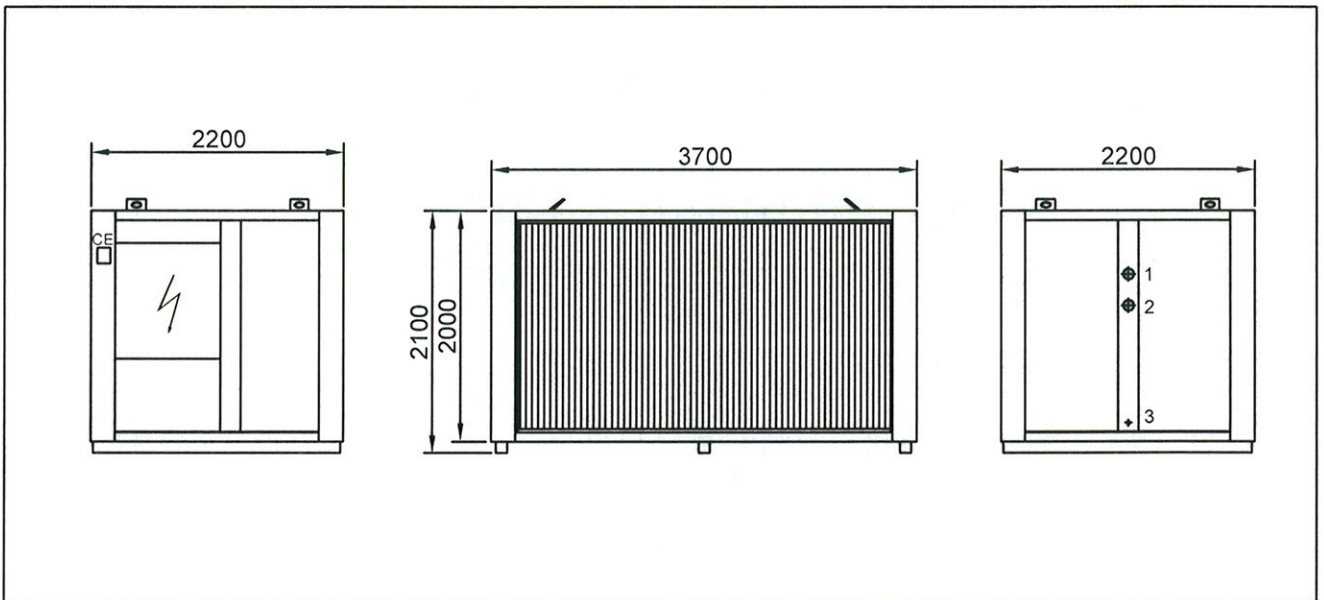

1	Ø3"	Entrata acqua - Water inlet - Entrée eau - Zufluss wasser - Entrada agua
2	Ø3"	Uscita acqua - Water outlet - Sortie eau - Ausfluss wasser - Salida agua
3	Ø1/2"	Scarico continuo - Contin. discharge - Ecoulement continu - Unaufhörliche -Entleerung - Descarga continuo

Potenza elettrica totale Total electric power Puissance électrique tot. Gesamtstromstärke Potencia eléctrica total	ass.	58,2 kW	Corrente Max Max. Current Courant max. Max. Spannung Corriente máx.	A	Magnetotermico Magnetothermic Switch Interr. Magnétothermique Magnetothermis. Schalter Interr. Magnetotérmico	A	Carica Gas R407C R407C Refrigerant Fill-up Charge gaz R407C Befüllung mit R407C Gas Carga gas R407C	kg
	inst.	90,0 kW		159		250		29

INDUSTRIAL FRIGO SI RISERVA IL DIRITTO DI MODIFICARE I DATI DELLA PRESENTE SCHEDA TECNICA IN QUALUNQUE MOMENTO
INDUSTRIAL FRIGO RESERVES THE RIGHT TO MODIFY THE DATA OF THIS TECHNICAL CARD IN ANY TIME, WITHOUT PRIOR NOTICE
INDUSTRIAL FRIGO SE RÉSERVE LE DROIT DE MODIFIER LE DONNÉES DE CETTE FICHE TECHNIQUE SANS PRÉAVIS
INDUSTRIAL FRIGO BEHÄLT SICH DAS RECHT VOR, DIE VORLIEGENDE DATEN OHNE VORHERIGE BENACHRICHTIGUNG ZU ÄNDERN
INDUSTRIAL FRIGO SE RESERVA EL DERECHO DE MODIFICAR LOS DATOS DE ESTA FICHA TECNICA UN CUALQUIER MOMENTO.

400V - 3 - 50Hz

01.12.06 P530022.01